

**Agency Approval**

Factory Mutual Approved Intrinsicly Safe for Hazardous Locations  
USA & Canada  
IS Class I, Division 1, Groups A, B, C, D  
T3C Ta = -40°C to 82°C; T4 Ta = -40°C to 66°C  
CL I Zone 0 AEx/Ex ia IIC  
T3 Ta = -40°C to 82°C; T4 Ta = -40°C to 66°C

**Ranges and Resolution**

See table below. Select range and default engineering unit.  
Units may be changed to any listed under the same sensor range.  
Resolution is fixed and limited to available display digits.

**Display**

3 readings per second nominal display update rate  
4 digit LCD, 0.5" H and 5 character 0.25" H alphanumeric

**BL:** Red LED backlight. Keypress activates backlighting for 1 minute if ambient light is insufficient.

**Accuracy**

Accuracy includes linearity, hysteresis, repeatability  
Standard accuracy: ±0.25% of full scale ±1 least significant digit  
**HA** accuracy option: ±0.1% FS ±1 LSD, see ranges for availability  
Sensor hysteresis: ±0.015% FS, included in accuracy  
Sensor repeatability: ±0.01% FS, included in accuracy

**Auto Shutoff**

5, 10, 30 minutes, or on/off. User selectable 1 minute to 8 hrs

**Memory Options**

Min/max can be user configured to be individually enabled or disabled, readings saved or cleared at power off  
Std: Min/max enabled

**M0:** Min/max turned off in user setup

**M1:** Peak reading only gauge for tire pressure

**Calibration**

Non-interactive zero, span, and linearity, ±10% of range Internal setup/calibration buttons, internal lockout switch.

**Controls and Functions**

Front button turns gauge on or off, zeros gauge reference gauges, and cycles through min/max functions (if enabled)  
Internal buttons for engineering unit selection, auto shutoff time, min/max setup, calibration  
Internal lockout switch to disable setup and calibration

**Batteries**

Two 1.5 V AAA Panasonic LR03 alkaline cells

**B:** Approx. 1000 hours

**BL:** Approx. 150 to 1000 hours depending on backlight usage  
Low battery symbol on display when batteries need replacement

**Weight**

9 ounces (approx.), shipping wt. 1 pound (approx.)

**Housing Materials and Circuit Board Protection**

Epoxy powder coated aluminum case, rear cover, and bezel. Front and rear rubber gaskets, polycarbonate label.  
Stainless steel stiffener plate to reinforce sensor area.  
Conformal coating on circuit boards for moisture resistance.

**Connection and Material**

1/4" NPT male fitting. All wetted parts are 316L stainless steel.

**Overpressure, Burst, Vacuum**

2 X pressure range for 3 psi to 2000 psi sensors  
5000 psig for ranges using 3000 psig sensor  
7500 psig for ranges using 5000 psig sensor  
Over-range display 112.5% FS: / - - - or / - - - -  
Under-range display (non-vacuum sensors): -Err  
Vacuum service: 15 psia, ±15 psig, 15 psig, 30 psia, 100 psig, 100 psia, 200 psig sensors

Burst: 4 X sensor pressure rating or 10,000 psi, whichever is less

**Environmental**

Storage temperature: -40 to 203°F (-40 to 95°C)  
Operating temperature: -4 to 185°F (-20 to 85°C)  
Compensated temperature: 32 to 158°F (0 to 70°C)

- ±0.25% Test Gauge Accuracy
- 316L Stainless Steel Sensor
- All Metal Housing



**Quick Link**  
[cecomp.com/is](http://cecomp.com/is)

Sensor Ranges and Engineering Units		* -HA option not available		Range codes are rounded off	
3 psig *	Res	15 psig vac *	Res	30 psia	Res
3PSIG	.001	100KPAVAC	.1	2KGCMA	.001
6INHG	.001	0.1MPAVAC	.0001	2ATMA	.001
85INH2OG	.1	1BARVAC	.001	30 psig	Res
50ZING	.01	1KGCMVAC	.001	30PSIG	.01
210GCMG	.1	1ATMVAC	.001	60INHGG	.01
150MMHGG	.1	15 psig	Res	850INH2OG	.1
150TORRG	.1	15PSIG	.01	480ZING	.1
200MBARG	.1	30INHGG	.01	2100GCMG	1
200CMH2OG	.1	400INH2OG	.1	1600MMHGG	.1
2000MMH2OG	1	240ZING	.1	1600TORRG	1
7FTH2O	.001	1000GCMG	1	2000MBARG	1
20KPAG	.01	760MMHGG	.1	2100CMH2OG	1
5 psig *	Res	760TORRG	.1	70FTH2O	.01
5PSIG	.001	1000MBARG	1	200KPAG	.1
10INHGG	.01	1000CMH2OG	1	0.2MPAG	.0001
140INH2OG	.1	35FTH2O	.01	2BARG	.001
80ZING	.1	100KPAG	.1	2KGCMA	.001
350GCMG	.1	0.1MPAG	.0001	2ATMG	.001
260MMHGG	.1	1BARG	1	60 psig	Res
260TORRG	.1	1KGCMA	1	60PSIG	.01
350MBARG	.1	1ATMG	1	120INHGG	.1
350CMH2OG	.1	±15 psig *	Res	1660INH2OG	1
3500MMH2OG	1	±15PSIVAC	.01	960ZING	1
12FTH2O	.01	15PSICPD	.01	4200GCMG	1
35KPAG	.01	±30INHGVAC	.01	3100MMHGG	1
15 psia	Res	±400INH2OVAC	1	3100TORRG	1
15PSIA	.01	±240ZINVAC	.1	4100MBARG	1
30INHGA	.01	±1000GCMVAC	1	4200CMH2OG	1
400INH2OA	.1	±760MMHGVAC	1	140FTH2O	.1
240ZINA	.1	±760TORRVAC	1	400KPAG	.1
1000GMA	1	±1000MBARVAC	1	0.4MPAG	.0001
760MMHGA	.1	±1000CMH2OVAC	1	4BARG	.001
760TORRA	.1	±100KPAVAC	.001	4KGCMA	.001
1000MBARA	1	±0.1MPAVAC	.0001	4ATMG	.001
1000CMH2OA	1	±1BARVAC	.001	100 psia	Res
100KPAA	.1	±1KGCMA	.001	100PSIA	.1
0.1MPAA	.0001	±1ATMVAC	.001	200INHGA	.1
1BARA	.001	30 psia	Res	2770INH2OA	1
1KGCMA	.001	30PSIA	.01	1600ZINA	1
1ATMA	.001	60INHGA	.01	7000GMA	1
15 psig vac *	Res	850INH2OA	1	200 psig	Res
15PSIVAC	.01	480ZINA	.1	200PSIG	.1
30INHGVAC	.01	2100GMA	1	400INHGG	.1
400INH2OVAC	.1	1600MMHGA	1	7000MBARA	1
240ZINVAC	.1	1600TORRA	1	5500INH2OG	1
1000GCMVAC	1	2000MBARA	1	3200ZING	1
760MMHGVAC	.1	2100CMH2OA	1	480FTH2O	.1
760TORRVAC	.1	200KPAA	.1	1400KPAG	.1
1000MBARVAC	1	0.2MPAA	.0001	1.4MPAG	.001
1000CMH2OVAC	1	2BARA	.001	7ATMA	.001
				14ATMG	.01

How to Specify	Display	Memory
DPG2000B range -D4-time-options	-	Min/max
DPG2000BBL range -D4-time-options	backlit	Min/max
DPG2000B range -D4-M0-time-options	-	Min/max off
DPG2000BBL range -D4-M0-time-options	backlit	Min/max off
DPG2000B range -D4-M1-time-options	-	Peak read
DPG2000BBL range -D4-M1-time-options	backlit	Peak read

**Range**—See table at left. Select a range code for default units. Please specify if vacuum gauge requires a minus sign.

psi = PSI                      torr = TORR                      mbar = MBAR  
inHg = INHG                  mmH2O = MMH2O                  bar = BAR  
oz/in<sup>2</sup> = ZIN                      kg/cm<sup>2</sup> = KGCM                      cmH2O = CMH2O  
inH2O = INH2O                  g/cm<sup>2</sup> = GCM                          atm = ATM  
ftH2O = FTH2O                  kPa = KPA  
mmHg = MMHG                  MPa = MPA

G = gauge reference pressure  
CPD = compound; inHg vacuum, psi pressure  
VAC = gauge reference vacuum  
A = absolute reference

Time—auto shutoff time	
5	5 minutes. Default if not specified.
10	10 minutes
30	30 minutes
ON	No auto shutoff. On/off via front button.
xH	Custom shutoff time where x = up to 8 hours

Options—add to end of model number. See price list for details.	
HA	High accuracy, ±0.1% FS ±1 LSD. See range table.
PM	Panel mount, 4.1" x 4.1"
TP	Top port, gauge port on top of case
CD	Calibration data; 5 test points and date
NC	NIST traceability documentation, 5 points and date

**TP**  
Top gauge port. Primarily used with tire pressure applications. Not available with NEMA 4X models.

**Accessories—order separately**

**RB**  
High visibility orange rubber boot protects gauge for portable applications. Not available with NEMA 4X models.

**SCR14SS**  
Filter screen fitting keeps debris out of gauge sensor. For food vacuum packaging applications. 303SS body, 100 micron 304SS screen.

**CON14SS**  
Quick connector to install or remove gauge without tools. 304 stainless steel, urethane seal.

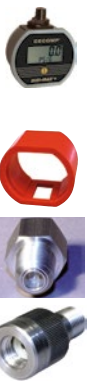

## Precautions

### Approved Locations

The DPG2000B series is approved for use in the following Hazardous Locations.

- IS Class I Div 1 Gp ABCD
- T3C Ta = -40°C to 82°C; T4 Ta = -40°C to 66°C.
- CL I Zone 0 AEx/Ex ia IIC
- T3 Ta = -40°C to 82°C; T4 Ta = -40°C to 66°C

### Installation

- ✓ Read these instructions before installing the gauge. Configuration may be easier before the gauge is installed. Contact the factory for assistance.
- ✓ Installation instructions must be strictly followed in compliance with Intrinsic Safety National Standard NEC 504 or ANSI/ISA RP 12.6 and the National Electrical Code.
- ✓ Outdoor or wash down applications require a NEMA 4X gauge or installation in a NEMA 4X housing.
- ✓ Use fittings appropriate for the pressure range of the gauge.
- ✓ Due to the hardness of stainless steel, it is recommended that a thread sealant be used to ensure leak-free operation.
- ✓ For contaminated media use an appropriate screen or filter to keep debris out of gauge port.
- ✓ Avoid permanent sensor damage! NEVER insert objects into gauge port or blow out with compressed air.
- ✓ Remove system pressures before removing or installing gauge.
- ✓ Install or remove gauge using a wrench on the hex fitting only. Do not attempt to turn by forcing the housing.

### Operation

- ✓ Use within the pressure range indicated on gauge label.
  - ✓ Avoid permanent sensor damage! Do not apply vacuum to gauges not designated for vacuum operation.
  - ✓ Use only with media compatible with 316L stainless steel.
  - ⚠ Gauges are not for oxygen service. Accidental rupture of sensor diaphragm may cause silicone oil inside sensor to react with oxygen.
  - ✓ The DPG2000B series gauges must only be operated in specified ambient temperature ranges.
- ### Maintenance
- ✓ The non-metallic cover of the pressure gauge is considered to constitute an electrostatic discharge hazard. Clean only with a damp cloth.
  - ✓ Batteries must be replaced when the low battery indication comes on to prevent unreliable readings.
  - ✓ WARNING: Replace batteries with approved type in non-hazardous locations only.
  - ✓ Approved batteries are two Panasonic LR03 1.5 V AAA alkaline cells. Replace both batteries at the same time.
  - ☒ WARNING: Substitution of batteries may impair intrinsic safety. Improper voltages will damage the gauge.
  - ✓ WARNING: Substitution of components may impair intrinsic safety. Do not modify the gauge.
  - ✓ These products do not contain user-serviceable parts except for batteries. Contact factory for repairs, service, or refurbishment.

## Battery Replacement

A low battery indication (either LOBAT or a  symbol depending on the model) will be shown in the upper left-hand corner of the display when the battery voltage falls sufficiently. The batteries should be replaced when the indicator comes on or unreliable readings may result.

WARNING: Replace batteries with approved type in non-hazardous locations only. Replace batteries with two Panasonic LR03 1.5 V AAA alkaline cells.

Replace both batteries with new ones at the same time. Do not mix different types of batteries. Substitution of components may impair intrinsic safety.

1. Remove the 6 Phillips screws on the back of the unit.
2. Remove batteries by lifting up the positive end of the battery (opposite the spring) taking care not to bend the spring.
3. Discard old batteries properly, do not discard into fire, sources of extreme heat, or in any hazardous manner.
4. Install batteries with correct orientation. The negative (flat) end of each battery should be inserted first facing the battery holder spring.
5. Replace the back cover, including the rubber gasket.

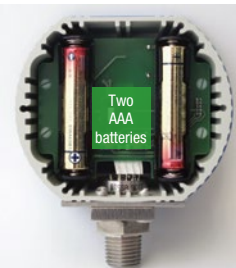

DS-DPG2000B rev. 12-12

## Dimensions

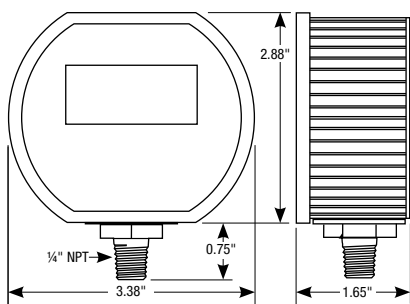

## Types of Gauges

Gauge reference reads zero with the gauge port open.

Bipolar ranges read positive pressure and vacuum in the same units, and zero with the gauge port open.

Compound ranges read positive pressure in psig and vacuum in inHg, and zero with the gauge port open.

Sealed reference reads zero with the gauge port open and is referenced to 14.7 psi. Used for 1000 psi and up.

Absolute reference reads atmospheric pressure with gauge port open and zero at full vacuum.

## Operation

### Power-Up

Press and hold the front button for approximately 1 second.

The display is tested, the full-scale range is indicated, the display segments are briefly shown again, then the actual pressure and units are displayed.

### Power Up with Zero

This applies to gauge reference models only. Absolute reference gauges do not use the zero feature since they read atmospheric pressure under normal conditions.



## Operation—continued

Be sure the gauge port is exposed to normal atmospheric pressure and no pressure is applied. The zeroing function is only activated at each power-up and the stored zero correction is erased when the gauge is shut off.

Press and hold the front button.

The display is tested.

Continue to press the button until *0000* is displayed.

Release the button. The gauge is now zeroed.

The full-scale range is indicated and the display segments are briefly shown again.

The actual pressure and units are displayed.

Attempting to zero the gauge with pressure greater than approximately 3% of full-scale pressure or vacuum applied will result in an error condition, and the display will alternately indicate *Err 0* and the actual measured pressure. The gauge must be powered down to reset the error condition.

### Normal Operation

Following the start-up initialization, the display indicates the pressure reading updated approximately 3 times per second. The auto shutoff timer starts when the gauge is powered up or whenever the button is pushed, unless the gauge shutoff time was set to zero for on/off operation.

If excessive vacuum is applied to a pressure-only gauge, the display will indicate *-Err* until the vacuum is released.

Applying vacuum to a gauge designed for pressure may damage the pressure sensor. If excessive pressure is applied (112.5% over range), an out-of-range indication of *1 - - -* or *1 - - -* will be displayed depending on model.

### Shut-Down

To shut off the gauge manually at any time, press and hold the button until the display indicates *OFF* (about 5 seconds) and then release.

When an auto shutoff timer is used, the display indicates *OFF* five seconds prior to auto shutoff. Pressed the button to keep the gauge on. The auto shutoff and backlight (if equipped) timers are reset whenever the button is pressed and released.

If the gauge set up without auto shutoff (on/off operation) it will stay on until manually shut off or until the batteries are depleted. Turn gauge off when not in use to conserve battery life.

## Operation—continued

### Display Backlighting (BL Option Only)

Display backlighting will operate when a button is pressed or held provided the front light sensor detects low ambient light levels. Display backlighting will turn on for one minute and then shut off. Backlighting may not be apparent under some lighting conditions.

### Minimum and Maximum Readings

Minimum and maximum readings are stored continuously whenever the gauge is on. The stored readings can be manually cleared if desired. The MIN and MAX memory can be configured to save or clear the reading whenever the gauge is off.

Press and hold the button for about 1 second until *MAX* is displayed alternating with the units. The maximum reading will be continuously updated. The gauge may be left in this mode. After *MAX* is displayed, press and hold the button for about 1 second until *MIN* is displayed alternating with the units. The minimum reading will be continuously updated. The gauge may be left in this mode. If excessive vacuum is applied to a pressure-only gauge while in this mode, the display will indicate *-Err* until the MAX/MIN readings are cleared.

After *MIN* is displayed, press and hold the button again for about 1 second until *\* \* \* \** is displayed. The MAX and MIN memory is not erased and the gauge returns to normal operation with the display indicating the current reading.

Press and continue to hold the button until the display indicates *clr MX/MN* (about 3 seconds total) and then release the button. Both maximum and minimum values are cleared and the gauge returns to the normal operating mode.

**M0 Models** are configured with minimum and maximum functions disabled. One or both can be enabled or disabled in the User Configuration mode.

**M1 Models** are peak reading gauges that only display and captures maximum readings. Press and hold the button for about 1 second until *MAX* is displayed alternating with the units. The maximum reading will be continuously updated. The MAX memory can be configured to save or clear the reading whenever the gauge is off.

## Basic Setup

Configuration must only be done in a non-hazardous area.

Remove the 6 Phillips screws on the back of the unit.

Remove the rear cover.

Move the switch on the circuit board to the ENABLE position.

Locate the UP and DOWN buttons on the circuit board.

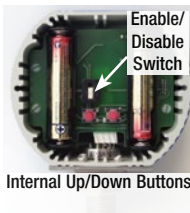

## Engineering Unit Selection

Engineering unit selection is done via internal buttons to help prevent accidental or unauthorized changes. The selected engineering unit is stored in non-volatile memory and will be retained even with the gauge off or batteries removed. The available engineering units depend on the sensor range and display resolution.

Compound (inHg/PSIG) gauges must be changed to display single-unit vacuum/pressure readings in the Advanced Configuration mode before different engineering units can be selected.

The default engineering units are mathematically converted to the newly selected engineering unit. When the gauge is powered up, the originally configured range is displayed and then the conversion with the selected engineering unit is displayed.

With the gauge powered up, press and hold the UP button. Release the button when the engineering units begin to flash.

Use the UP and DOWN buttons to scroll through the list of engineering units available for the pressure range of the sensor.

When the desired units are displayed, press and release the front button to save the selection and return to normal operation.

Note: The gauge will automatically revert to normal operation if no buttons are operated for approximately 15 seconds.

If done, replace the rear cover, or proceed to the next step.

## Auto Shutoff Time Selection

Auto shutoff time selection is done via internal buttons to help prevent accidental or unauthorized changes. The selected shut off time is stored in non-volatile memory and will be retained even with the battery off or batteries removed.

With the gauge powered up, press and hold the DOWN button. Release the button when the auto shutoff time is displayed on the upper section.

The lower display will indicate *AST M* if the time displayed is in minutes, and *AST H* if it in hours.

An auto shutoff time of 0 signifies that the auto shutoff feature is disabled and the front button turns the gauge on and off.

Use the UP and DOWN buttons to select 0, 1, 2, 5, 10, 15, 20 or 30 minutes, or 1, 2, 4, or 8 hours.

When the desired time is displayed, press and release the front button to save the selection and return to normal operation.

Note: The gauge will automatically revert to normal operation if no buttons are operated for approximately 15 seconds.

Move the switch on the circuit board to the DISABLE position and replace the rear cover including the rubber gasket.

## Entering User Configuration

Configuration must only be done in a non-hazardous area.

Remove the 6 Phillips screws on the back of the unit and remove the rear cover.

Move the switch on the circuit board to the ENABLE position.

Locate the UP and DOWN buttons on the circuit board.

## User Configuration Access

With the gauge off, press and hold the UP button. Then press the front button. Release all buttons when the display indicates *CFG* and the program version. Then the full-scale range is indicated and the display is tested.

The display then indicates *\_ \_ \_ \_* with the first underscore blinking, with *CFGPC* (configuration pass code) on the lower display.

Note: The gauge will automatically revert to normal operation if no buttons are pressed for approximately 15 seconds. To cancel and return to normal operation, press and release the front button without entering any pass code characters.

## User Configuration Pass Code Entry

The factory default is 3510, but this may be changed by the user under the Pass Code Configuration section. If an incorrect pass code is entered, the gauge will return to the start of the pass code entry sequence.

1. Use the UP or DOWN buttons to set the first digit to 3.
2. Press and release the front button to move to the next position. The 3 will remain, and the second position will be blinking.
3. Use the UP or DOWN buttons to select 5.
4. Press and release the front button to index to the next position. 35 will remain, and the third position will be blinking.
5. Use the UP or DOWN buttons to select 1.
6. Press and release the front button to index to the next position. 351 will remain, and the fourth position will be blinking.
7. Use the UP or DOWN buttons to select 0.
8. Press and release the front center button to proceed.

## User Configuration

### Factory/User Configuration

This gives the choice of resetting the gauge features to the factory settings or continuing with user configuration.

The upper display section will be blank, and the lower section will display either *USER\_* or *FCTRY*.

If *FCTRY* is selected, the existing user configuration will be replaced by the original factory configuration.

To select *FCTRY*, press and release the UP button.

With *FCTRY* displayed press and release the front button to restore the factory configuration and restart the gauge.

If *USER\_* is selected, the user configuration can be modified as described in the following steps.

To select *USER\_*, press and release the DOWN button.

With *USER\_* displayed press and release the front center button to continue.

The configuration parameters vary depending on the model. Go to the appropriate section for your gauge.

### M0, M2 Max/Min Configuration

Use the UP and DOWN buttons to select from the following:

- MX/MN* Both highest and lowest values will be captured
- MX/--* Only highest value will be captured
- /MN* Only lowest value will be captured
- /--* Capture feature is disabled

Press and release the front button to move to the next parameter.

### M0, M2 Max/Min Memory

The upper display section will indicate *c / r*.

Use the UP and DOWN buttons to select from the following:

*AUTO* Automatically clear max. and min. values when the gauge is powered off

*MAN* Manually clear max. and min. values

Press and release the front button to move to the next parameter.

### M1 Peak Reading Gauge

You can select whether to retain maximum captured values at power off.

The upper display section will indicate *c / r*.

Use the UP and DOWN buttons to select from the following:

*AUTO* Automatically clear the maximum stored value when the gauge is powered off

*MAN* Save the maximum stored value when the gauge is powered off. It must be cleared manually.

Press and release the front button to move to the next parameter.

### Gauge Type Configuration

This will only appear with 15, 100, or 200 psig ranges that were originally ordered as compound gauges.

Use the UP and DOWN buttons to select from the following:

*-/+EU* Vacuum is indicated as negative pressure in the selected engineering units

*CMPND* Vacuum is negative INHG, pressure is PSIG. This setting will disable engineering unit selection.

Press and release the front button to save the user configuration and restart the gauge.

This completes the configuration for this model. Move the switch on the circuit board to the DISABLE position and replace the rear cover including the rubber gasket.

**Calibration Preparation**

Calibration must only be done in a non-hazardous area. See Installation and Precautions.

Gauges are calibrated at the factory using equipment traceable to NIST. There is no need to calibrate the gauge prior to use.

Calibration should only be performed by qualified individuals using appropriate calibration standards and procedures.

Contact factory if assistance is required. Gauges can be returned to factory for certified calibration and repairs. NIST traceability is available.

Calibration intervals depend on your quality control program requirements. Many customers use an annual calibration cycle.

The calibration equipment should be at least four times more accurate than the gauge being calibrated.

The calibration system must be able to generate and measure pressure and/or vacuum over the full range of the gauge.

A vacuum pump able to produce a vacuum of 100 microns (0.1 torr or 100 millitorr) or lower is required for vacuum and absolute gauges.

Warning: Never apply vacuum to gauge not designated for vacuum service. Permanent sensor damage may result.

It is good practice to install fresh batteries before calibration.

Allow the gauge to equalize to normal room temperature (about 20 minutes minimum) before calibration.

**Calibration**



Internal Up/Down Buttons

See Calibration Preparation section. See rear label of gauge for model identification and range.

Remove the 6 Phillips screws on the back of the unit and remove the rear cover.

Move the switch on the circuit board to the ENABLE position.

Locate the internal UP and DOWN buttons on the circuit board.

**Entering Calibration Mode**

With the gauge off, press and hold the DOWN button, then press the front button.

Release all buttons when the display indicates *CAL*.

The display begins by indicating the full-scale positive pressure rating of the gauge in the engineering units as configured by the factory, and then shows all display segments.

Before the gauge enters the calibration mode, the display initially indicates      with the first underscore blinking, with *CALPC* (calibration pass code) on the lower display.

Note: The gauge will automatically revert to normal operation if no buttons are operated for approximately 15 seconds. To cancel and return to normal operation, press and release the front without entering any pass code characters.

Enter the pass code as described in the User Configuration Pass Code Entry section. The default is 3510, but this is user changeable.

**Calibration Mode**

The gauge remains in the calibration mode until restarted manually or power is removed. Features not related to calibration are disabled.

The calibration may be performed in any of the available engineering units as well as percent (PCT). Compound range models are set for the same engineering units for pressure and for vacuum.

For greatest calibration accuracy, use the UP and DOWN buttons to select engineering units with highest number of display counts.

Press and release the front button when the desired engineering units are displayed.

**Calibration—continued**

Sensor	Suggested units for calibration
3 PSI	3.000 PSI
5 PSI	5.000 PSI
15 PSI	775.7 MMHG (TORR)
30 PSI	69.20 FTH2O
60 PSI	60.00 PSI
100 PSI	7.031 KG/CM2
200 PSI	407.2 INHG
300 PSI	610.8 INHG
500 PSI	500.0 PSI
1000 PSI	70.31 KG/CM2
3000 PSI	6108 INHG
5000 PSI	5000 PSI
Any	100.00 PCT (percent)

The display will then indicate the currently applied pressure in the engineering units selected for calibration.

**UP and DOWN Button Operation**

Each time one of the UP or DOWN buttons is pressed and released quickly, a small change is made to the digitized pressure signal. It may take more than one of these small changes to result in a single digit change on the display.

To make larger changes, press and hold the appropriate UP or DOWN button. After about one second, the display will begin to change continuously. Release the button to stop. Then make fine adjustments by pressing and quickly releasing the appropriate button.

**Gauge Reference Pressure Gauges**

Apply zero pressure by venting the gauge port to atmosphere. The character display will alternate between *ZERO* and *CAL*.

Press the UP and DOWN buttons to obtain a zero indication on the gauge display.

Apply full-scale pressure. The character display will alternate between *+SPAN* and *CAL*.

Press the UP and DOWN buttons to match the gauge display to the full-scale pressure reading on the calibrator.

Apply 50% full-scale pressure. The character display will alternate between *+MID* and *CAL*.

Press the UP and DOWN buttons to match the gauge display to the 50% of full-scale pressure on the calibrator.

**Gauge Reference Vacuum Gauges**

Apply zero pressure by venting the gauge port to atmosphere. The character display will alternate between *ZERO* and *CAL*.

Press the UP and DOWN buttons to obtain a zero indication on the gauge display.

Apply full-scale vacuum. The character display will alternate between *+SPAN* and *CAL*.

Press the UP and DOWN buttons to match the gauge display to the full-scale vacuum indication on the calibrator.

Apply 50% full-scale vacuum. The character display will alternate between *+MID* and *CAL*.

Press the UP and DOWN buttons to match the gauge display to the 50% of full-scale vacuum indication on the calibrator.

**Absolute Reference Gauges**

Apply full vacuum. The character display will alternate between *ZERO* and *CAL*.

Press the UP and DOWN buttons until the display indicates zero.

Apply full-scale pressure. The character display will alternate between *+SPAN* and *CAL*.

Press the UP and DOWN buttons to match the gauge display to the full-scale pressure reading on the calibrator.

Apply 50% of full-scale pressure. The lower display will alternate between *+MID* and *CAL*.

Press the UP and DOWN buttons to match the gauge display to the 50% of full-scale reading on the calibrator.

**Compound and Bipolar Gauges**

In addition to the steps described above for pressure gauges, apply full-scale vacuum. The character display will alternate between *-SPAN* and *CAL*.

Press the UP and DOWN buttons to match the gauge display to the full-scale vacuum reading on the calibrator.

**Calibration—continued**

For bipolar ( $\pm$ ) and  $-30.00\text{inHg}/+15.00\text{psig}$  compound range models only, apply 50% full-scale vacuum. The character display will alternate between *-MID* and *CAL*.

Press the UP and DOWN buttons to match the gauge display to the 50% of full-scale vacuum on the calibrator.

**Save Calibration**

Once the adjustments are complete, press and hold the front button until the display indicates *- - - -* then release the button to store the calibration parameters in non-volatile memory and restart the gauge.

Verify the pressure indications at 0%, 25%, 50%, 75% and 100% of full scale.

Move the switch on the circuit board to the DISABLE position.

Replace the back cover, including the rubber gasket.

**User Pass Code**

User-defined pass code configuration allows changing of the factory 3510 pass code to new value for configuration and calibration.

Configuration must only be done in a non-hazardous area.

Remove the rear 6 Phillips screws and remove the rear cover.

Move the switch on the circuit board to the ENABLE position.

Locate the internal UP and DOWN buttons on the circuit board.

**View Or Change User Configuration Pass Code**

With the unit off, press and hold the UP button, then press the front button. Release all buttons when the display indicates *CFG*.

**View Or Change User Calibration Pass Code**

With the unit off, press and hold the DOWN button, then press the front button. Release all buttons when *CAL* is shown.

**Enter Access Code 1220**

Before the unit enters the view or change pass code mode, the display initially indicates      with the first underscore blinking, and with *CFGPC* or *CALPC* on the lower display.

Note: The gauge will automatically revert to normal operation if no buttons are operated for approximately 15 seconds.

To cancel and return to normal operation, press and release the front button without entering any pass code characters.

Use the UP, DOWN, and front buttons to enter the 1220 pass code.

Press and release the front button to proceed.

Note: If an incorrect access code was entered, the gauge will return to the start of the access code entry sequence.

Once the access code has been entered correctly, the display will indicate the existing user-defined pass code with either *CFGPC* or *CALPC* on the character display.

1. Press the UP or DOWN button to select the first character of the new pass code.
2. When the desired first character is displayed, press and release the front button to move to the next character.
3. Repeat above until the entire pass code is complete.
4. To exit, press and hold the front button. Release the button when the display indicates *- - - -* to restart the gauge.
5. Move the switch on the circuit board to the DISABLE position.
6. Replace the back cover, including the rubber gasket.

CECOMP maintains a constant effort to upgrade and improve its products. Specifications are subject to change without notice. Consult factory for your specific requirements.