

- 100 Ω Platinum RTD
- 316 Stainless Steel Probe
- 2 wire 4-20 mA Output with Programmable Range
- -58.0°F to 392.0°F or -50.0°C to 200.0°C
- NEMA 4X Housing
- Spring-Loaded Versions for Thermowells

Specifications

Range and Resolution

User selectable °F or °C
 -58.0°F to 392.0°F
 -50.0°C to 200.0°C
 0.1 degree resolution

Typical Accuracy

Includes linearity error and ±1 LSD
 11-point linearization
 ±0.7°C at -50°C
 ±0.4°C at 0°C
 ±0.9°C at 100°C
 ±1.4°C at 200°C

Display

4 readings per second nominal display update rate
 4 digit LCD, 0.5" H
 5 character 0.25" H alphanumeric
 ☺ Low loop voltage indication
 ALARM1 under range indication on display
 ALARM2 over range indication on display

Sensor

IEC-751 Class B 100 Ω Platinum RTD, 0.00385 alpha curve
 1/2" NPT male, 316L stainless steel
 All wetted parts are 316L stainless steel
 Thermowell required for spring-loaded versions
 Spring-loaded probe fits standard thermowells
 Fixed probe pressure rating: 5000 psi max.
 Fixed probes are welded to hex fitting

Analog Output

12,000 count 4-20 mA output
 Updated approximately 4 times per second
 Temperature range configurable to correspond to 4-20 mA output
 Configurable for upscale or downscale burnout

Controls and Functions

3 button front keypad for setup, calibration, and configuration.
 User-defined pass codes to prevent unauthorized changes.
 Pass code required for configuration and calibration.

Output Test Function

When TEST button is held loop current and display are set to test level, independent of temperature input, to allow testing of system operation. Test level is user set.
 Output test function can be pass code protected

Calibration

User settable pass code required to enter calibration mode
 Zero and span temperature calibration
 Non-interactive zero, span, and linearity,
 ±10% of range

Power

Any DC supply/loop resistance that maintains 8 to 32 VDC at gauge terminals
 Reverse polarity protected
 3 ft long, 2-conductor 22 AWG cable

Weight

Product: 12 ounces (approximately)
 Shipping: 1 pound (approximately)

Housing Materials

ABS/polycarbonate NEMA 4X case, rear gasket, polycarbonate label, aluminum sensor block

Storage Temperature

-40 to 203°F (-40 to 95°C)

Operating Range

-4 to 185°F (-20 to 85°C) at housing



Quick Link
cecomp.com/ThermoPro

See thermowell manufacturer's specifications. Probe length is measured from top of full threads to tip of probe.

Dimensions

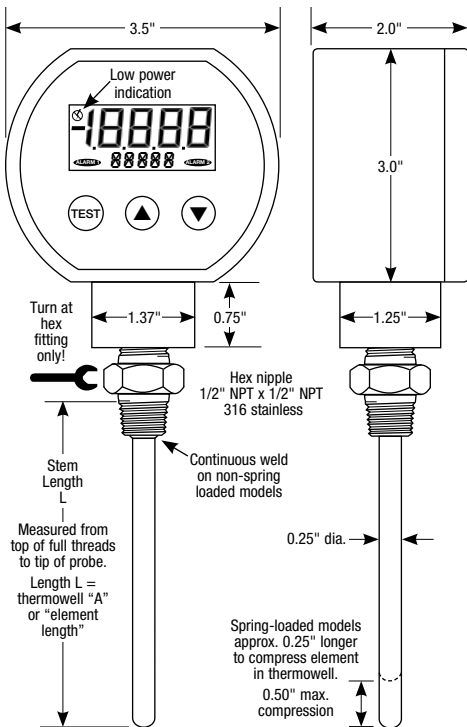

Wiring

Connection to the T16L is made with the 2-wire cable at the gauge rear. Reversing the connections will not harm the gauge but it will not operate with incorrect polarity. See the wiring examples below for connecting to a 4-20 mA current loop.

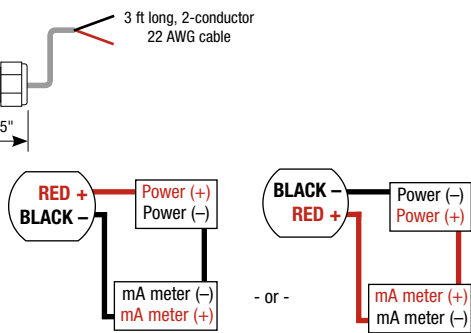

If the 4-20 mA analog output is not required, the transmitter will function as a low voltage powered temperature indicator when connected to any 8 to 32 VDC power supply. Connect the loop (+) supply to the RED lead and the loop (-) supply to the BLACK lead.



How to Order

Spring-loaded RTD probes MUST be used with a thermowell. Length = thermowell "S", "L", "A" or "stem length" dimension. See your thermowell manufacturer's specifications. NOTE: probe length is NOT the same as thermowell insertion depth.

Consult factory for custom probe lengths.

Model	Length
T16L2	2.5" L fixed length
T16L4	4" L fixed length
T16L6	6" L fixed length
T16L9	9" L fixed length
T16L12	12" L fixed length
T16L2S	2.5" L spring-loaded
T16L4S	4" L spring-loaded
T16L6S	6" L spring-loaded
T16L9S	9" L spring-loaded
T16L12S	12" L spring-loaded

If you require a certain programming configuration to be pre-set from the factory, please indicate it on your order.

- Option—add to end of model number**
- CC** Conformal coating on circuit board for moisture resistance

Cecomp maintains a constant effort to upgrade and improve its products. Specifications are subject to change without notice. Consult factory for your specific requirements.

Installation and Precautions

Read these instructions before installation. Configuration may be easier before installation.

Avoid shock hazards! Turn power off before connecting or disconnecting wiring. All wiring must be performed by a qualified electrician or instrumentation technician. See diagrams on other side for wiring examples. Consult factory for assistance.

Install or remove thermometer using a wrench on the hex fitting only. Do not attempt to turn by forcing the housing.

Do not exceed maximum allowable housing temperature.

The spring-loaded design must be used with a thermowell.

The fixed probe design can be used in applications with low or no material flow. Due to the hardness of 316 stainless steel, it is recommended that a thread sealant be used to ensure leak-free operation.

Loop Voltage

Select a loop power supply voltage and total loop resistance so that when the loop current is 20 mA, the transmitter will have at least 8 VDC at its terminals. For correct operation, the terminal voltage must never fall below 8 VDC. Below about 7.8 VDC erratic operation may occur. Too large a loop resistance will cause the output to "limit" or saturate before reaching its full 20 mA output. The minimum loop supply voltage may be calculated from the formula:

$$V_{min} = 8V + (20mA \times \text{Total loop resistance})$$

This is an indication that the loop supply/resistance may not allow adequate headroom for reliable operation. This should never occur in normal use. If it does, examine the loop supply/resistance.

Normal Operation

To turn the unit on, apply power. The ThermoPro is designed for continuous operation. Warm-up time is negligible.

When power is first applied, the ThermoPro will set the loop current to maximum and check the voltage available. If there is sufficient voltage available to power the unit, all active segments will be displayed briefly. Then the display and the loop current will correspond to the temperature of the RTD probe.

At power-up, if the voltage available is not sufficient, only the low power indicator will be displayed. This is an indication that the loop impedance is too high or the loop power supply voltage is too low.

After successful power-up, if the loop voltage falls below the minimum required for reliable operation, the ThermoPro will continue to indicate the temperature of the RTD with the low power indicator blinking at a slow rate.

Out-of-Range Indications

RTD over-range condition >392.0°F or >200.0°C

RTD under-range condition <-58.0°F or <-50.0°C

If the RTD temperature is outside of the extrapolated range, a burnout condition is assumed.

1. . . . if upscale burnout is selected. The loop current will be at 20 mA.

-1. . . . if downscale burnout is selected. The loop current will be 4 mA.



User Configuration Mode

From the normal operating mode, press and hold  and then press the TEST button until CFG is displayed.

When the buttons are released the upper display will indicate _ _ _ _ with the left position blinking, and the lower display will indicate PASS.

Pressing and releasing TEST exits configuration. The unit will automatically revert to normal operation if no buttons are operated for approximately 15 seconds.

Enter the user-defined pass code (3510 factory default).

Use the  and  buttons to increase or decrease the numerical value.

Press and release the TEST button to index to the next position.

If an incorrect pass code was entered, the gauge will exit to the normal operating mode.

Press and release the TEST button to proceed to the configuration sequence.

Temperature Scale Selection

The upper display will be blank, and the lower section will display DEG C or DEG F.

To change from Celsius to Fahrenheit, press and release the  button. The lower display will change to DEG F.

To change from degrees Fahrenheit to Celsius, press and release the  button. The lower display will change to DEG C.

Whether or not a change is made, the Test value will be reset to 0.0°C or to 32.0°F.

Press and release the TEST button to move on to the next parameter.

Upscale/Downscale Burnout

The upper display will be blank, and the lower display will indicate UP BO or DN BO.



To change from upscale burnout to downscale burnout, press and release the  button. The display will change to DN BO.

To change from downscale burnout to upscale burnout, press and release the  button. The display will change to UP BO.



Press and release the TEST button to move on to the next parameter.

Output Range

The upper display will indicate the temperature corresponding to a loop current of 4 mA. The lower display will indicate RINGLO.



To change the temperature corresponding to a loop current of 4 mA, use the  and  buttons to set the desired value. Press and release the TEST button to move on to the next parameter.

The upper display will indicate the temperature corresponding to a loop current of 20 mA. The lower display will indicate RINGHI.

To change the temperature corresponding to a loop current of 20 mA, use the  and  buttons to set the desired value.

Press and release the TEST button to save the configuration parameters and restart the gauge. The configuration parameters will not be saved if the procedure is interrupted before completion.

Output Test Level

To set the test output level, press and hold the front-panel TEST button and press the  and  buttons to adjust the test output to the desired temperature setting. This setting is stored in non-volatile memory.

When the TEST button is held depressed, the display and loop current are switched, independent of the RTD temperature, to a level determined by the test setting. When the button is released, normal operation is resumed.

Calibration Mode

The ThermoPro is factory calibrated and there is generally no need to alter calibration settings. Required calibration equipment includes a temperature reference and milliamp meter of at least four times the unit's accuracy, a dry-block calibrator or temperature controlled bath, and a DC loop power supply. Connect the ThermoPro according to the current loop wiring diagram with a milliamp meter in series with the circuit.

Temperature calibration is performed at ice point and at a temperature above ice point. The full scale temperature is normally used for the second point. However, if a particular temperature is of critical interest, it may be used instead for best accuracy at that point.

From the normal operating mode, press and hold the  and then press TEST.

Release buttons when CAL is shown.

Enter the user-defined pass code as described under User Configuration Mode.

Upon successful pass code entry, the upper display will indicate the RTD probe temperature. The lower will alternate CAL and the temperature units.

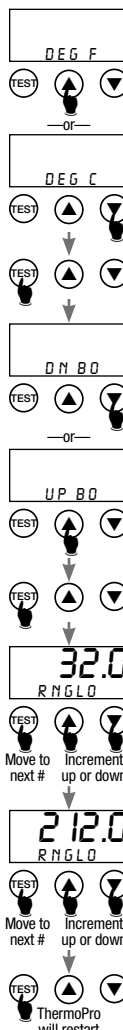



Loop Calibration

Note: to store the calibration parameters and exit calibration mode at any time, press and hold the TEST button for more than 2 seconds until the display indicates - - - - .



Press the TEST button and release it when the display indicates LCAL. During loop calibration only the loop current will change. The pre-configured temperatures will not change.

The upper display will indicate the temperature corresponding to 4 mA loop current. The lower display will alternate between CAL and 4 MA.

Use the  and  buttons to adjust the actual loop current to 4 mA.

Press the TEST button and release it when the display indicates HCAL.



The upper display will indicate the pre-configured temperature corresponding to a 20 mA loop current. The lower display will alternate between CAL and 20 MA.

Use the  and  buttons to adjust the actual loop current to 20 mA.



Ice Point Calibration

Press the TEST button and release it when the display indicates CAL.

Apply 0.0°C or 32.0°F to the RTD. At approximately 12°C (or 54°F), the ice-point calibration mode will automatically be selected.

The lower display will alternate between ICEO and DEG C or DEG F. Use the  and  buttons to adjust the upper display to indicate 0.0°C or 32.0°F.

Second Point Calibration

Apply full-scale temperature to the RTD. The lower display will alternate between CAL and DEG C or DEG F. Use the  and  buttons to adjust the upper display to indicate the applied temperature value.



To store the calibration parameters and exit calibration mode, press and hold the TEST button until the display indicates - - - - . The unit will restart in the normal mode.

Change Pass Code



From the normal operating mode, press and hold  and then press the TEST button until CFG is displayed.



When the buttons are released the upper display will indicate _ _ _ _ with the left position blinking, and the lower display will indicate PASS.

Pressing and releasing TEST exits configuration. The unit will automatically revert to normal operation if no buttons are operated for approximately 15 seconds or if an incorrect pass code was entered.

Enter pass code 1220 (factory default). Use the  and  buttons to increase or decrease the numerical value. Press and release the TEST button to index to the next position.

After 1220 has been entered press and release the TEST button to proceed to the pass code change sequence.

The present pass code will be displayed. Operate the  or  button to select the first character of the new pass code.

Press and release the TEST button to proceed to the next character. Repeat until the new pass code is complete and the last number stops blinking. To correct any entry errors press the  or  button again. Write down the new pass code in a secure place.

To exit, press and hold the TEST button until the display indicates - - - - . The unit will restart in the normal mode.

