

- ±0.25% Test Gauge Accuracy
- 316 Stainless Steel Wetted Parts
- Capture Minimum and Maximum Readings

- Selectable Units
- Selectable Auto Shutoff Times
- Zero Function

Specifications

Ranges and Resolution

See table below. Any engineering units equivalent to the PSI range can be ordered as the default range. Resolution is fixed for each engineering unit

Accuracy

Includes linearity, hysteresis, repeatability
Standard: ±0.25% of full scale ±1 least significant digit
-HA: ±0.1% FS ±1 LSD (see Options for availability)

Display

3 readings per second nominal display update rate
4 digit LCD, 0.5" H and 5 character 0.25" H alphanumeric
BL models: red LED backlight

Batteries, Battery Life, Low Battery Indication

B: 2 AA alkaline, approx. 2000 hours
BL: 2 AA alkaline, approx. 150 to 1500 hours depending on backlight usage
Low battery symbol on display

Controls & Functions

Front button turns gauge on or off, zeros gauge reference gauges, and cycles through min/max functions
Internal push buttons for calibration and selection of engineering units and auto shutoff times
BL: Front button activates backlighting for 1 minute

Min/Max Functions

Minimum and maximum readings stored 4 times per second
Front button cycles through min display, max display, clear
Configurable for min only, max only, both, or none
Configure to clear min/max at power off or retain min/max at power off

Calibration

Pass code protected calibration
Non-interactive zero, span, and linearity, ±10% of range

Auto Shutoff

User selectable 1 minute to 8 hours or front button on/off
Factory default 5 minutes, unless other time is specified

Weight

Gauge: 9 ounces (approximately)
Shipping: 1 pound (approximately)

Material

F18B: Extruded aluminum case, epoxy powder coated, ABS/ polycarbonate bezel (aluminum bezel optional), front and rear gaskets, polycarbonate label
F18BN: ABS/polycarbonate NEMA 4X case, rear gasket, polycarbonate label

Connection, Material, Media Compatibility

1/4" NPT male fitting, 316L stainless steel
All wetted parts are 316L stainless steel
Compatible with most liquids and gases

Overpressure

3000 psig range: 5000 psig
5000 psig range: 7500 psig
All others: 2 X pressure range
112.5% FS out-of-range display: | --- or | - - - -

Burst Pressure

4 X sensor pressure rating, or 10,000 psi, whichever is less

Storage Temperature

-40 to 203°F (-40 to 95°C)

Operating Temperature

-4 to 185°F (-20 to 85°C)

Compensated Temperature

32 to 158°F (0 to 70°C)

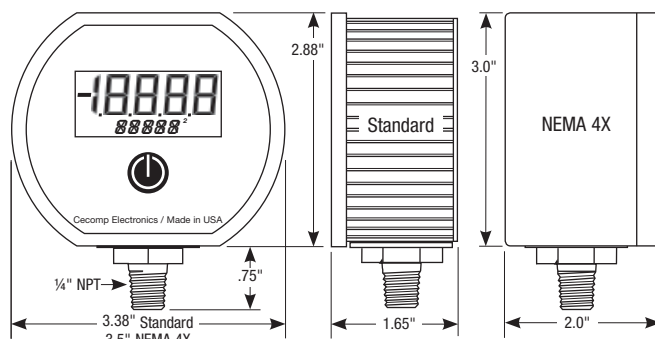

How to Order

Please Specify

Model Range - Shutoff* - Options

Specify pressure or vacuum range and units. Include gauge or absolute reference as applicable.

If vacuum gauge requires a minus sign, please specify.

*Only specify if default time is to be other than 5 minutes

Model	Features
F18B	Standard housing
F18BBL	Standard housing, backlit display
F18BN	NEMA 4X housing
F18BNBL	NEMA 4X housing, backlit display

Options—add to end of model number

- HA High accuracy, ±0.1% FS ±1 LSD. Not available with vacuum, compound, bipolar, absolute, or 3 psi sensor ranges.
- PM Panel mount, 4.1" x 4.1". Not available with NEMA 4X models.
- MC Metal front cover. Machined aluminum, epoxy powder coated. Synthetic oil resistant. Not available with NEMA 4X models.
- CS Case stiffener strengthens case bottom for tire pressure applications.
- CC Conformal coating on circuit board for moisture resistance.
- SM Surface mount plate. Battery gauges only. Not available with NEMA 4X models.
- TP Top port, gauge port on top of case. Used primarily for tire pressure applications.

Accessories

- RB Protective rubber boot. Not for NEMA 4X models.
- CD Calibration data, 5 test points, test date.
- NC NIST certificate with traceability documentation, 5 test points and date.

Range Code	Default Range	Selectable Engineering Units. See table on next page for specific ranges.															
-30V15PSIG *	-30.0 inHg to 15.0 PSIG	±PSIG	±inHg	±inH2O	±oz/in ²	±g/cm ²	±mmHg	±torr	±mbar	±bar	±cmH2O	±kPa	±MPa	±kg/cm ²	±atm		
-30V100PSIG *	-30.0 inHg to 100.0 PSIG	±PSIG	±inHg	±inH2O	±oz/in ²		±mmHg	±torr	±bar			±kPa	±MPa	±kg/cm ²	±atm		
-30V200PSIG *	-30.0 inHg to 200.0 PSIG	±PSIG	±inHg	±inH2O	±oz/in ²				±bar			±kPa	±MPa	±kg/cm ²	±atm		
3PSIG	0 to 3.000 PSIG		inHg	inH2O	oz/in ²	g/cm ²	mmHg	torr	mbar	bar	mmH2O	cmH2O	ftH2O	kPa	kg/cm ²	atm	
5PSIG	0 to 5.000 PSIG		inHg	inH2O	oz/in ²	g/cm ²	mmHg	torr	mbar	bar	mmH2O	cmH2O	ftH2O	kPa	kg/cm ²	atm	
15PSIA	15.00 to 0 PSIA		inHg	inH2O	oz/in ²	g/cm ²	mmHg	torr	mbar	bar		cmH2O		kPa	MPa	kg/cm ² atm	
15PSIVAC	0 to -15.00 PSIG		inHg	inH2O	oz/in ²	g/cm ²	mmHg	torr	mbar	bar		cmH2O	ftH2O	kPa	MPa	kg/cm ² atm	
±15PSIG	±15.00 PSIG	±inHg	±inH2O	±oz/in ²	±g/cm ²	±mmHg	±torr	±mbar	±bar		±cmH2O	±ftH2O	±kPa	±MPa	±kg/cm ²	±atm	
15PSIG	0 to 15.00 PSIG		inHg	inH2O	oz/in ²	g/cm ²	mmHg	torr	mbar	bar		cmH2O	ftH2O	kPa	MPa	kg/cm ² atm	
30PSIA	0 to 30.00 PSIA		inHg	inH2O	oz/in ²	g/cm ²	mmHg	torr	mbar	bar		cmH2O		kPa	MPa	kg/cm ² atm	
30PSIG	0 to 30.00 PSIG		inHg	inH2O	oz/in ²	g/cm ²	mmHg	torr	mbar	bar		cmH2O	ftH2O	kPa	MPa	kg/cm ² atm	
60PSIG	0 to 60.00 PSIG		inHg	inH2O	oz/in ²	g/cm ²	mmHg	torr	mbar	bar		cmH2O	ftH2O	kPa	MPa	kg/cm ² atm	
100PSIA	0 to 100.0 PSIA		inHg	inH2O	oz/in ²	g/cm ²	mmHg	torr	mbar	bar		cmH2O		kPa	MPa	kg/cm ² atm	
100PSIG	0 to 100.0 PSIG		inHg	inH2O	oz/in ²	g/cm ²	mmHg	torr	mbar	bar		cmH2O	ftH2O	kPa	MPa	kg/cm ² atm	
200PSIG	0 to 200.0 PSIG		inHg	inH2O	oz/in ²					bar		ftH2O	kPa	MPa	kg/cm ² atm		
300PSIG	0 to 300.0 PSIG		inHg							bar		ftH2O	kPa	MPa	kg/cm ² atm		
500PSIG	0 to 300.0 PSIG		inHg							bar		ftH2O	kPa	MPa	kg/cm ² atm		
1000PSIG	0 to 1000 PSIG		inHg							bar		ftH2O	kPa	MPa	kg/cm ² atm		
2000PSIG	0 to 2000 PSIG		inHg							bar		ftH2O		MPa	kg/cm ² atm		
3000PSIG	0 to 3000 PSIG		inHg							bar		ftH2O		MPa	kg/cm ² atm		
5000PSIG	0 to 5000 PSIG		inHg							bar				MPa	kg/cm ² atm		

*Compound ranges can be set up as either compound (inHg/psig only) or bipolar (±) with selectable units in pass code protected user configuration mode only.

Power-Up

Press and hold the front button for approximately 1 second.

The display segments are tested.

The full-scale range is indicated and the display segments are briefly shown again.

The actual pressure and units are displayed.

Power-Up With Zero

This applies to gauge reference models only. Absolute reference gauges do not use the zero feature since they read atmospheric pressure under normal conditions.

Be sure the gauge port is exposed to normal atmospheric pressure and no pressure is applied. The zeroing function is only activated at each power-up and the stored zero correction is erased when the gauge is shut off.

Press and hold the front button.

The display segments are tested.

Continue to press the button until 0000 is displayed.

Release the button. The gauge is now zeroed.

The full-scale range is indicated and the display segments are briefly shown again.

The actual pressure and units are displayed.

Attempting to zero the gauge with pressure greater than approximately 3% of full-scale pressure or vacuum applied will result in an error condition, and the display will alternately indicate Err 0 and the actual measured pressure. The gauge must be powered down to reset the error condition.

Normal Operation

Following the start-up initialization, the display indicates the pressure reading updated approximately 3 times per second. The auto shutoff timer starts when the gauge is powered up or whenever the button is pushed, unless the gauge shutoff time was set to zero for on/off operation.

If excessive vacuum is applied to a pressure-only gauge, the display will indicate -Err until the vacuum is released.

Applying vacuum to a gauge designed for pressure may damage the pressure sensor. If excessive pressure is applied (112.5% over range), an out-of-range indication of 1 --- or 1.-- will be displayed depending on model.

Display Backlighting (BL models only)

Display backlighting can be turned on by momentarily pressing the front button whenever the gauge is on. The backlighting will turn on for one minute and then automatically shut off. This also restarts the auto shutoff timer. The display backlighting will not be apparent under bright lighting conditions.

Minimum and Maximum Readings

Gauges are normally configured with minimum and maximum capture functions enabled. One or both can be disabled in the User Configuration mode.

Minimum and maximum readings are continuously stored and updated whenever the gauge is on. The stored readings can be manually cleared if desired. The MAX and MIN memory is also cleared whenever the gauge is off unless configured to save the readings.

Press and hold the button for about 1 second until MAX is displayed alternating with the units. The maximum reading will be continuously updated. The gauge may be left in this mode.

After MAX is displayed, press and hold the button for about 1 second until MIN is displayed alternating with the units. The minimum reading will be continuously updated. The gauge may be left in this mode. If excessive vacuum is applied to a pressure-only gauge while in this mode, the display will indicate -Err until the MAX/MIN readings are cleared.

After MIN is displayed, press and hold the button again for about 1 second until * * * * is displayed. The MAX and MIN memory is not erased and the gauge returns to normal operation with the display indicating the current reading.

Press and continue to hold the button until the display indicates clr MX/MN (about 3 seconds total) and then release the button. Both maximum and minimum values are cleared and the gauge returns to the normal mode and displays the current pressure.

Shut-Down

To shut off the gauge manually at any time, press and hold the button until the display indicates OFF (about 5 seconds) and then release.

When an auto shutoff timer is used, the display indicates OFF five seconds prior to auto shutoff. The button can be pressed to keep the gauge on. The auto shutoff and backlight (if equipped) timers are reset whenever the button is pressed and released.

If the gauge set up without auto shutoff (on/off operation) it will stay on until manually shut off or until the batteries are depleted. Turn gauge off when not in use to conserve battery life.

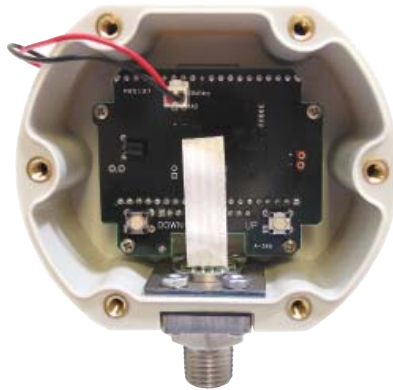

Engineering Unit Selection

Engineering unit selection is done via internal buttons to help prevent accidental or unauthorized changes. The selected engineering unit is stored in non-volatile memory and will be retained even with the gauge off or batteries removed. The available engineering units depend on the sensor range and display resolution.

Compound (inHg/PSIG) gauges must be changed to display single-unit vacuum/pressure readings in the Advanced Configuration mode before different engineering units can be selected.

The default engineering units are mathematically converted to the newly selected engineering unit. When the gauge is powered up, the originally configured range is displayed and then the conversion with the selected engineering unit is displayed.

To change engineering units remove the rear cover to gain access to the two internal buttons located near the lower right and left corners of the circuit board.

With the gauge powered up, press and hold the UP button. Release the button when the engineering units begin to flash.

Use the UP and DOWN buttons to scroll through the list of engineering units available for the pressure range of the sensor.

When the desired units are displayed, press and release the front button to save the selection and return to normal operation.

Note: The gauge will automatically revert to normal operation if no buttons are operated for approximately 15 seconds.

Replace the rear cover taking care not to pinch the power wires between the cover and the case.

Auto Shutoff Time Selection

Auto shutoff time selection is done via internal buttons to help prevent accidental or unauthorized changes. The selected shut off time is stored in non-volatile memory and will be retained even with the battery off or batteries removed.

Remove the rear cover to gain access to the two internal buttons located near the lower right and left corners of the circuit board.

With the gauge powered up, press and hold the DOWN button. Release the button when the auto shutoff time is displayed on the upper section.

The lower display segments will indicate AST M if the time displayed is in minutes, and AST H if it in hours.

An auto shutoff time of 0 signifies that the auto shutoff feature is disabled and the front button turns the gauge on and off.

Use the UP and DOWN buttons to select 0, 1, 2, 5, 10, 15, 20 or 30 minutes, or 1, 2, 4, or 8 hours.

When the desired time is displayed, press and release the front button to save the selection and return to normal operation.

Note: The gauge will automatically revert to normal operation if no buttons are operated for approximately 15 seconds.

Replace the rear cover taking care not to pinch the power wires between the cover and the case.

Advanced Configuration

User Configuration

User configuration allows requires a pass code for access and allows more features to be configured.

Remove the rear cover to gain access to the buttons located near the lower right and left corners of the circuit board.

With the gauge off, press and hold the UP button. Then press the front button. Release all buttons when the display indicates CFG and the program version then the full-scale range is indicated and the display segments are tested.

The display then indicates _ _ _ _ with the first underscore blinking, and with CFGPC (configuration pass code) on the character segments.

Note: The gauge will automatically revert to normal operation if no buttons are operated for approximately 15 seconds. To cancel and return to normal operation, press and release the front button without entering any pass code characters.

User Configuration Pass Code Entry

The factory default is 3510, but this may be changed by the user under the Pass Code Configuration section.

1. Use the UP or DOWN buttons to set the left-most digit to 3.
2. Press and release the front button to move to the next position. The 3 will remain, and the second position will be blinking.
3. Use the UP or DOWN buttons to select 5.
4. Press and release the front button to index to the next position. 35 will remain, and the third position will be blinking.

5. Use the UP or DOWN buttons to select 1.
6. Press and release the front button to index to the next position. 351 will remain, and the fourth position will be blinking.
7. Use the UP or DOWN buttons to select 0.
8. Press and release the front button to proceed with configuration procedures.

If an incorrect pass code is entered, the gauge will return to the start of the pass code entry sequence.

Factory/User Configuration

The upper display section will be blank, and the lower section will display either USER_ or FCTRY.

If USER_ is selected, the user configuration can be modified as described in the following steps.

To select USER_, press and release the DOWN button.

The lower display will indicate USER_.

Press and release the front button to continue.

If FCTRY is selected, the existing user configuration will be replaced by the original factory configuration.

To select FCTRY, press and release the UP button.

The lower display will indicate FCTRY.

Press and release the front button to restore the factory configuration and restart the gauge.

Max/Min Configuration

Use the UP and DOWN buttons to select from the following:

- MX/MN Both highest and lowest values will be captured
- MX/-- Only highest value will be captured
- /MN Only lowest value will be captured
- /-- Capture feature is disabled

Press and release the front button to move to the next parameter.

Max/Min Memory

The upper display section will indicate clr.

Use the UP and DOWN buttons to select from the following:

- AUTO Automatically clear max. and min. values when the gauge is powered off
- MAN Manually clear max. and min. values

Press and release the front button to move to the next parameter.

Gauge Type Configuration

This will only appear with 15, 100, or 200 psig ranges that were originally ordered as compound gauges.

Use the UP and DOWN buttons to select from the following:

- /+EU Vacuum is indicated as negative pressure in the selected engineering units
- CMPND Vacuum is negative INHG, pressure is PSIG. This setting will disable engineering unit selection.

Press and release the front button to save the user configuration and restart the gauge.

Replace the rear cover taking care not to pinch the power wires between the cover and the case.